



Aviat Networks Investor Presentation

Fiscal Q2 2025

February 4, 2025

Forward-Looking Statements

The information contained in this presentation includes forward-looking statements within the meaning of the safe harbor provisions of the U.S. Private Securities Litigation Reform Act of 1995, including Aviat's outlook, business conditions, new product solutions, customer positioning, future orders, bookings, new contracts, cost structure, profitability in fiscal 2025, its recent acquisitions and acquisition strategy, process improvements, measures designed to improve internal controls, plans and objectives of management, realignment plans and review of strategic alternatives and expectations regarding future revenue, gross margin, Adjusted EBITDA, operating income or earnings or loss per share. All statements, trend analyses and other information contained herein about the markets for the services and products of Aviat Networks, Inc. and trends in revenue, as well as other statements identified by the use of forward-looking terminology, including "anticipate," "believe," "plan," "estimate," "expect," "goal," "will," "see," "continue," "delivering," "view," and "intend," or the negative of these terms or other similar expressions, constitute forward-looking statements. These forward-looking statements are based on estimates reflecting the current beliefs of the senior management of Aviat Networks, Inc. These forward-looking statements involve a number of risks and uncertainties that could cause actual results to differ materially from those suggested by the forward-looking statements.

For more information regarding the risks and uncertainties for our business, see "Risk Factors" in our most recent Form 10-K filed with the U.S. Securities and Exchange Commission ("SEC"), as well as other reports filed by Aviat Networks, Inc. with the SEC from time to time. Aviat Networks, Inc. undertakes no obligation to update publicly any forward-looking statement for any reason, except as required by law, even as new information becomes available or other events occur in the future.

Company Overview

Aviat Networks is the leading wireless transport and access solutions provider

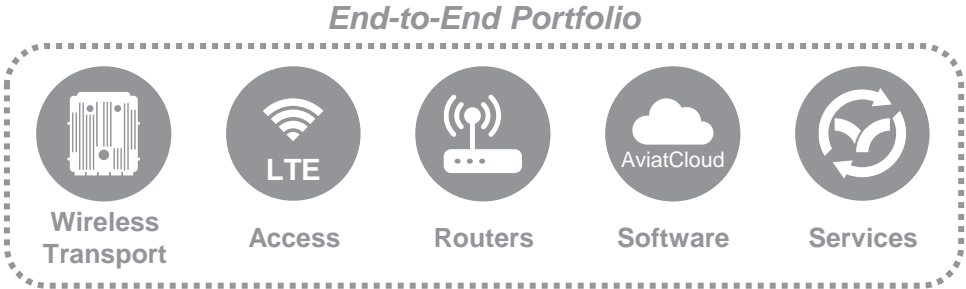

NASDAQ Listed: AVNW

Headquartered in Austin, TX

3,000+ Customers Worldwide

Global Manufacturing Capabilities

Leading Technologies – 175+ Patents

Revenue Summary

LTM Revenue: \$434 Million

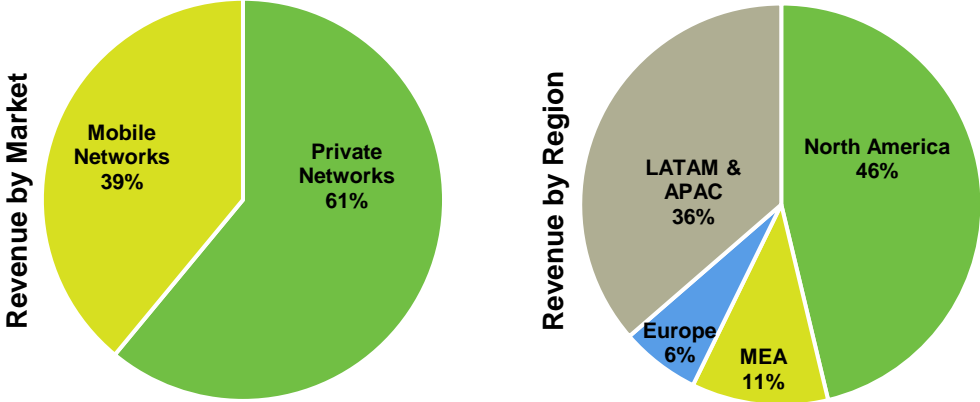

Points of Excellence

- Lowest Total Cost of Ownership
- Mission Critical Solutions Leader
- Unrivalled Microwave Expertise
- Innovative Products and Services

Over 75 Years of Expertise

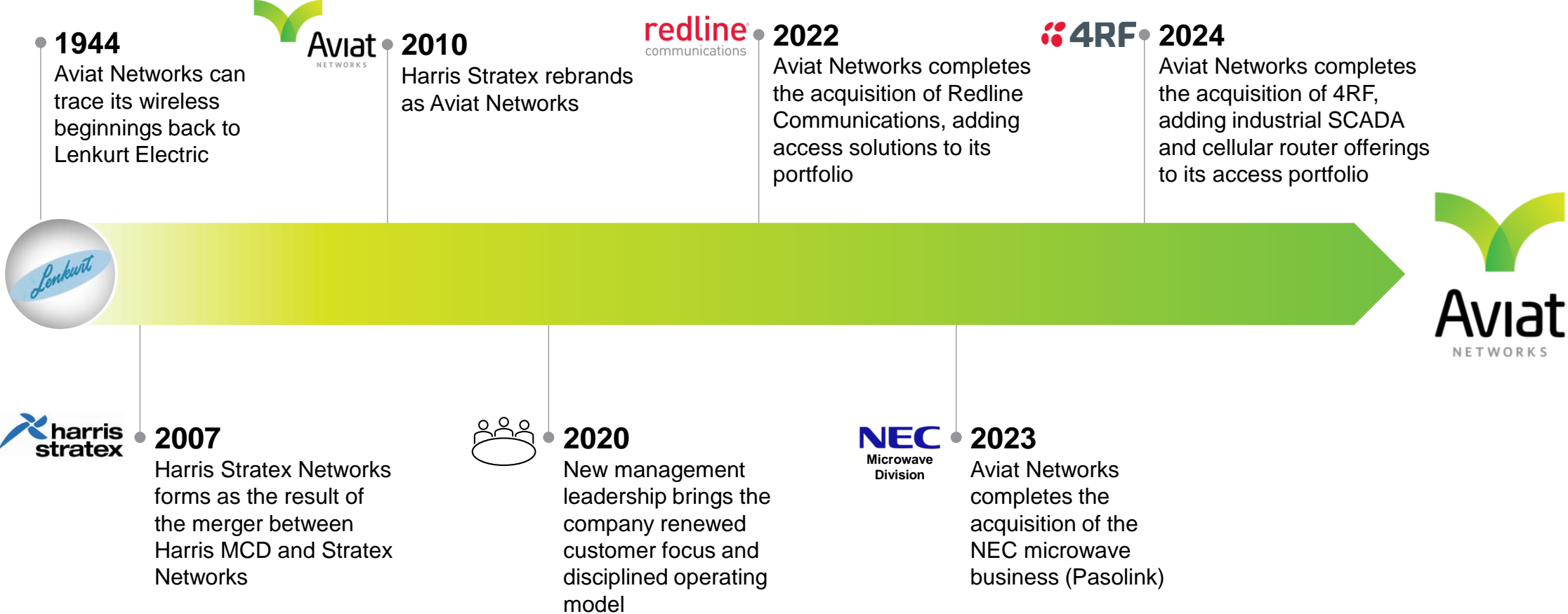

A Long History of Wireless Leadership Invigorated by New Leadership and Consistent Execution

Investment Opportunity

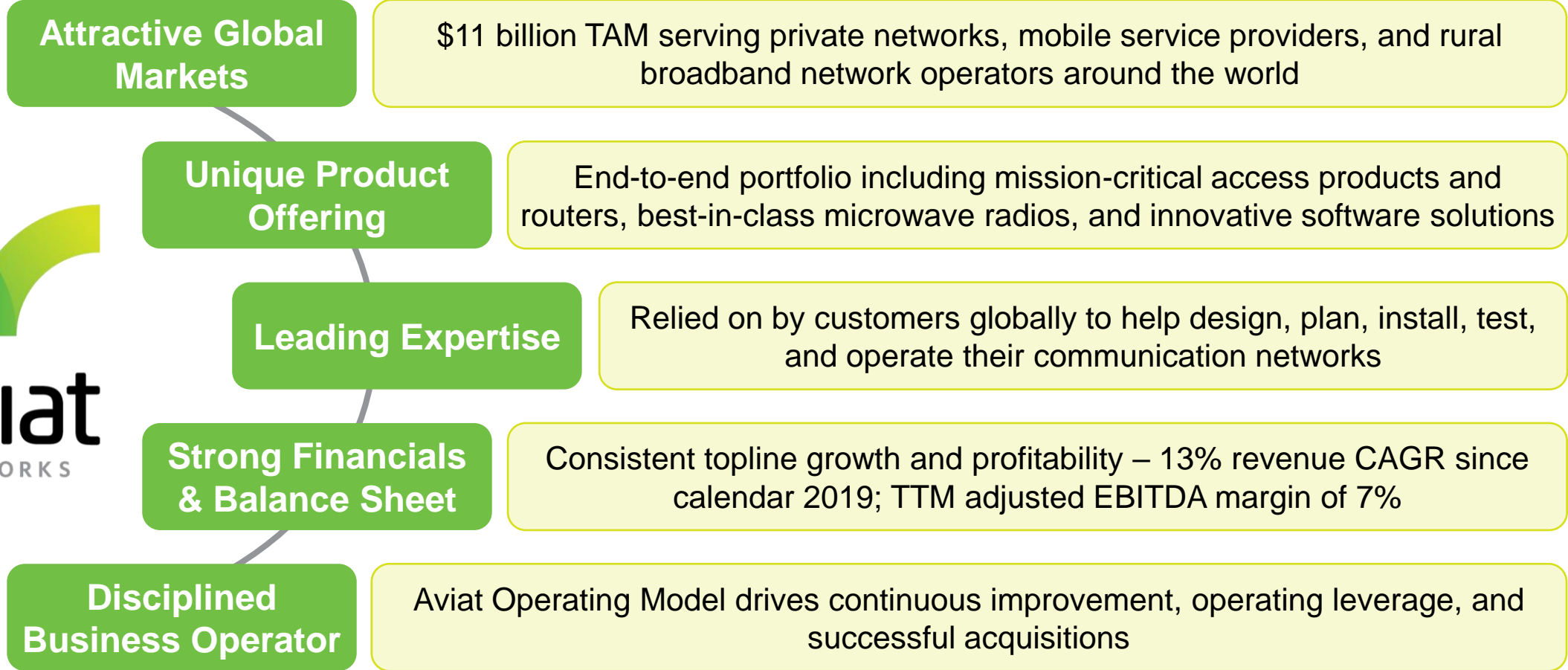

Global Investment in Mission Critical, 5G, and Rural Broadband Networks Underpin Strong and Growing Demand Environment

Why Aviat Wins

	Aviat's Competitive Advantage	vs. Microwave Specialists	vs. Wireless Generalists
Products	<ul style="list-style-type: none"> ✓ Modular radio platform ✓ End-to-end offering of radios, multi-band, routers, access ✓ Better RF performance 	<ul style="list-style-type: none"> • Highly leveraged in chipsets • Difficult to create new product variants quickly • Unable to invest in routing and other products 	<ul style="list-style-type: none"> • Microwave not focus • Less responsive and agile to bringing radio solutions to market
Software & Services	<ul style="list-style-type: none"> ✓ Turnkey services portfolio (design, planning, install) ✓ Software innovations to ease network operations and total cost of ownership (AviatCloud, Assurance software) 	<ul style="list-style-type: none"> • Product focus and lack of software investment • Lack of experience and services make competing in private networks difficult 	<ul style="list-style-type: none"> • Lack focus on dedicated software solutions for transport networks
Supply Chain	<ul style="list-style-type: none"> ✓ Core competence – fast deliveries and disruptive go-to-market like the Aviat Store 	<ul style="list-style-type: none"> • Lack modularity limits supply chain flexibility • Unable to create new business models or react to Aviat innovations 	<ul style="list-style-type: none"> • Microwave supply chain not a priority vs. RAN • Cannot react to Aviat innovations

Aviat Provides More Innovation and Better Value Than Our Competitors

Wireless Transport and Access Markets Overview

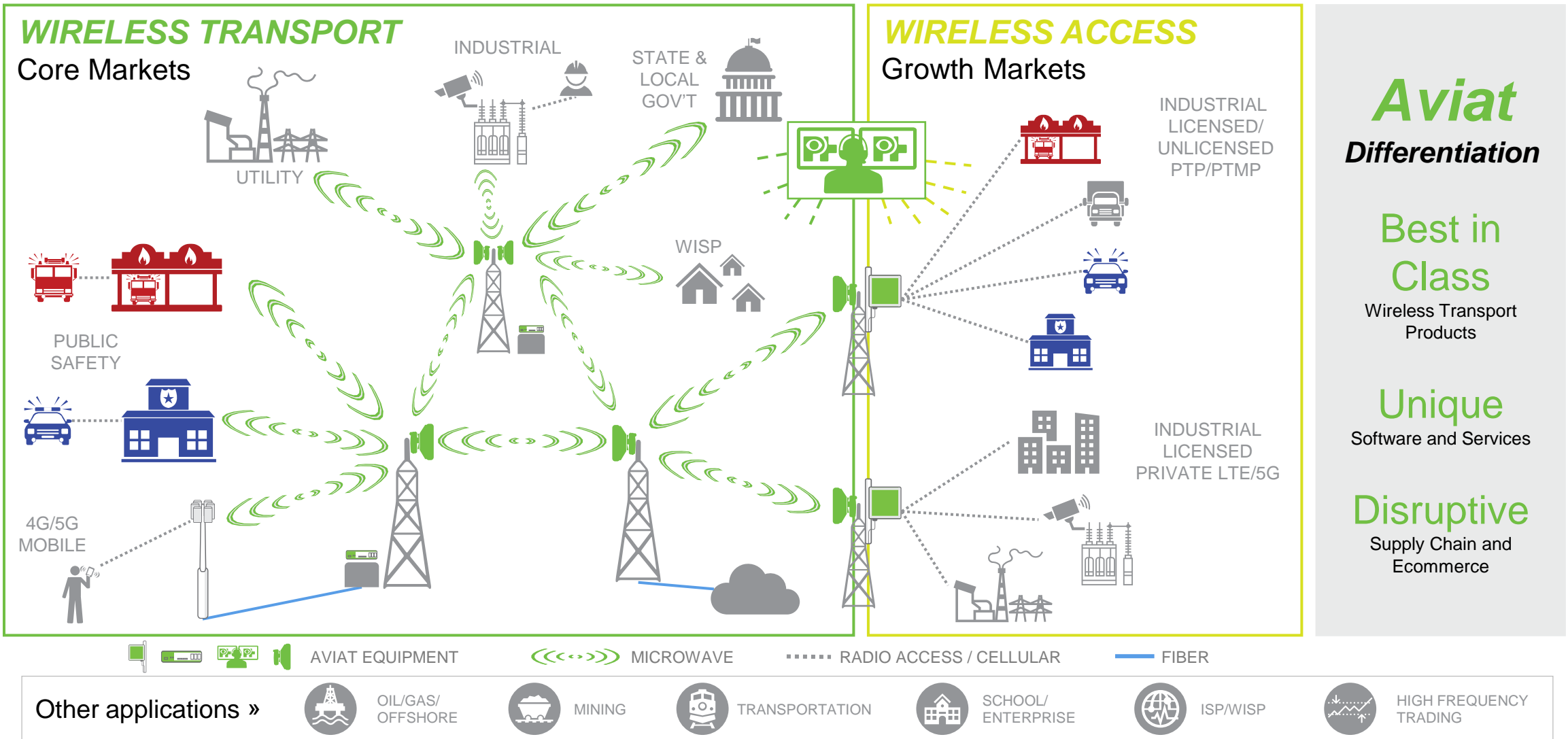

Aviat Differentiation Aligned with Private Networks, 5G and Rural Broadband

Aviat Product Portfolio



Health Assurance (HAS)

Detailed reports on network issues
Reduces downtime



ProVision Plus Network/Element Management

Simplifies network management
Easy trouble shooting with multi-layer visualization



Frequency Assurance (FAS)

Monitors and reports Interference
Protects against WiFi-6E



Split-Mount Systems

iPasolink VR

- 6 to 38GHz freq. band
- Sub-band free ODU options
- Modular and scalable indoor units
- Standard and High-Power Outdoor Units
- No single point of failure options

Markets: Mobile Service Providers, Utilities, Public Safety, Oil & Gas, Mining, Transportation



All-Outdoor Systems

WTM 4000, EX/A, EX/AD

- Single, Dual Channel or Multi-Band
- Full IP/ MPLS Capabilities
- Unique Multi-Band extended distance and vendor agnostic options
- 25GbE connectivity

Markets: Mobile Service Providers, WISPs, Utilities, Public Safety, Oil & Gas, Mining, Transportation

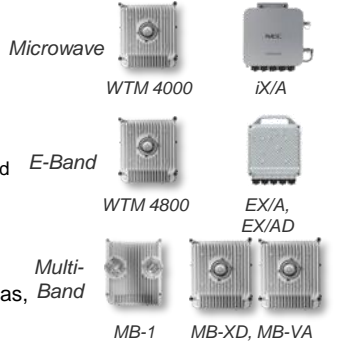

Private LTE/5G

RDL 6000, Aprisa LTE/5G, Aviat Core

- Base station, LTE/5G routers and EPC Core
- Power of a Macro in Small Cell footprint
- Lower power consumption
- Scalable EPC
- Ruggedized, secure cellular routers

Markets: Utilities, Public Safety, Oil & Gas, Mining, Transportation



Trunking Systems

STR 4500, OBC2, 7000iP TRP

- Split Mount, All-Indoor, and All-Outdoor Trunking Systems
- Up to 20 channels with diversity
- 10Gbps connectivity
- Flexible aggregation options

Markets: Mobile Service Providers, Utilities, Public Safety, Oil & Gas, Mining, Transportation



Indoor Radio

IRU600, TRP, Eclipse

- Ultra-High Tx Power, +37dBm
- Compact/expandable antenna branching
- Tough, Durable and Dependable
- Comprehensive native TDM features
- Strong Security (FIPS)

Markets: Utilities, Public Safety, Oil & Gas, Mining, Transportation

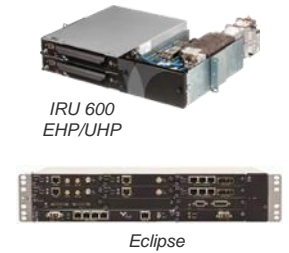

Microwave Routers

CTR8000 Series

Markets: Mobile Service Providers, WISPs, Utilities, Public Safety, Oil & Gas, Mining, Transportation



Industrial Access

Narrowband PTP, PTMP and Nomadic Solutions

- PTP, PTMP licensed and unlicensed
- UHF, VHF, 220MHz - 5.8GHz
- Hardened and secure
- Innovative nomadic, self align offering
- ATEX/Hazloc

Markets: Utilities, Public Safety, Oil & Gas, Mining, Transportation



Wireless Transport

Wireless Access

Portfolio Focused on Lowering Total Cost of Ownership

AVIAT NETWORKS

How Aviat Lowers Total Cost of Ownership

1. Reduced Tower Footprint

What: Lower power consumption, faster installation, smaller antennas, reduced tower loading, lower lease costs

How: Fewer boxes, high system gain, Multi-Band

2. Capacity Scalability

What: Less congestion, fewer truck rolls, less hardware

How: Multi-Band, A2C+, on-demand capacity upgrades

3. Integrated Routing

What: Reduced or zero indoor footprint, fewer boxes, simplified operations, lower power consumption

How: All-Outdoor at the edge, CTR/WTM integrated IP/MPLS

4. Spectrum Fee Savings

What: Reduced recurring spectrum fees

How: Moving capacity from Microwave to E-Band and Multi-Band

5. Higher Network Reliability

What: Better performance, increased resilience, fewer outages, faster fault-finding/restoration, lower OPEX

How: High MTBF, High Availability Routing, Aviat Assurance Software (HAS, FAS)

6. Simplified Logistics

What: Easy online design and ordering, fast delivery, Reduced inventory and warehouse costs

How: Aviat Design, Aviat Store, regional stock, on-demand capacity and license upgrades



Microwave is a Crucial Backhaul Technology



Microwave



Fiber

Speed to Deploy	✓	
High Reliability	✓	
Low Latency	✓	
Terrain Flexibility	✓	
Capacity		✓
Cost	Per Link	Per Foot

Microwave is ideally suited for mission-critical private networks, rural broadband, and challenging deployment environments

Wireless transport accounts for 60% of cellular transport links

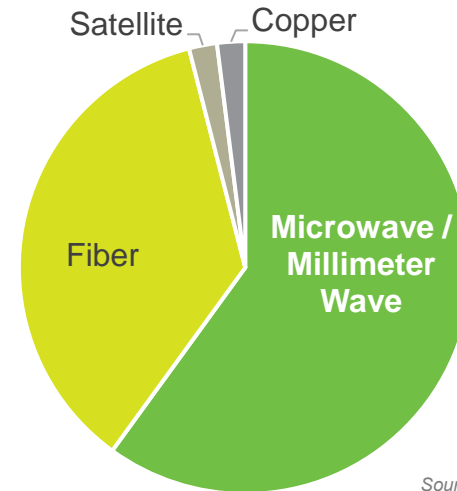

Source: Dell 'Oro; Excludes North East Asia

Service providers rely on microwave in their networks to provide cost-effective and reliable bandwidth

Microwave Backhaul is Essential in Communication Networks Globally

Aviat's Market Opportunities

Private Networks

- Upgrade cycle in public safety, utilities and other private networks driven by increasing bandwidth needs
- Private LTE / 5G market to be \$8B by 2027
- Aviat's end-to-end product and services allow for increasing share of wallet capture and competitive advantage

Mobile Networks & 5G

- Early stages of global 5G upgrade cycle; mobile network data traffic expected to grow at 26% CAGR through 2028
- Wireless transport makes up 60% of cellular transport links
- Microwave radio market for global 5G transport market expect to grow at a 39% CAGR through CY2025

Rural Broadband

- Over \$70 billion in U.S. government funding programs to build out rural broadband networks
- Microwave is a compelling solution for operators to lower total cost of ownership and increase speed to deploy
- Aviat's unique e-commerce platform allows for direct to network operator channel

Aviat Networks is Capturing Additional Market Share Because of Its Innovative Portfolio and Focus on Lowest Total Cost of Ownership

Private Network Summary

Growth Drivers

- Growth in Private LTE and Industrial IoT driven by video and modern applications
- States and municipalities upgrading their public safety communications
 - State and local budgets remain healthy; growing public safety funding
- American Rescue Plan Act (ARPA) funding of \$350 billion for U.S. States' water, sewer, public safety, and broadband infrastructure
- Vendor outsourcing and declining microwave expertise creates share of wallet opportunities

Segments Addressed

Public Safety and Security



Oil & Gas

Water

Electric Utilities



National / Regional Government

Enterprise



Aviat's Leadership

- Mission critical product differentiation
 - Highest powered radios
 - Ruggedized access products & cellular router
 - IP/MPLS integration
 - Software innovations to simplify network management (PV+, HAS, FAS)
- Strong state relationships and global partners
- Differentiated services offerings
 - Network design and testing
 - Install
 - Support
 - Managed services (incl. NOC)

Aviat Offers a Compelling Value Proposition to Private Network Operators

Mobile Networks & 5G Market Summary

- Mobile service provider market driven by increasing bandwidth demand in 4G and 5G networks
 - Data from global networks is anticipated to grow rapidly (26% CAGR) through 2028, driven by 5G adoption and expanding 4G networks
- Aviat's product portfolio enables operators to increase their network capacity while lowering total cost of ownership (TCO)
 - **Single-box multi-band** lowers tower leasing costs while increase capacity
 - **Vendor-agnostic multi-band** allows operators to utilize existing radios and layer on Aviat's solution, lowering the barrier to entry for Aviat into a network
 - **Multi-band XD** enables longer distances between links which helps to minimize total network capex
 - **Highest capacity** radio available on the market (20 Gbps)
- Aviat's multi-band is up to \$10,000/link lower TCO vs competitive multi-band offerings
 - **Superior** solution → **Less** hardware → **Lowest** TCO

Global 5G Wireless Transport Market

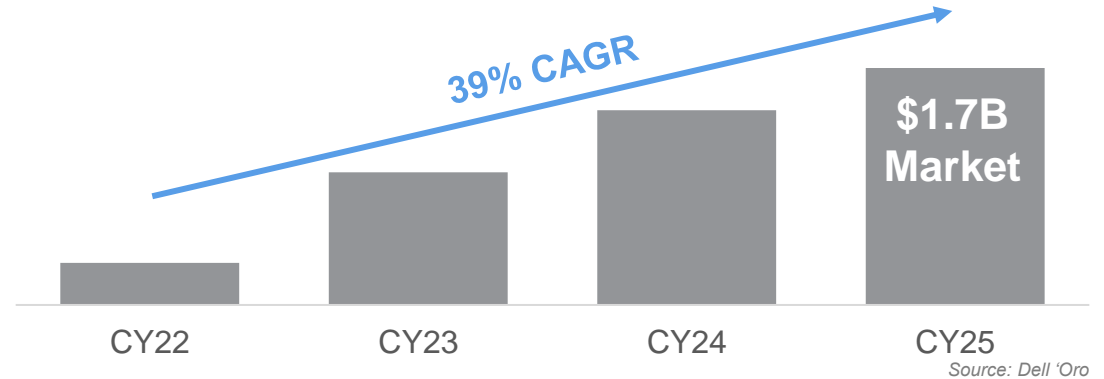

Global Mobile Network Data Traffic

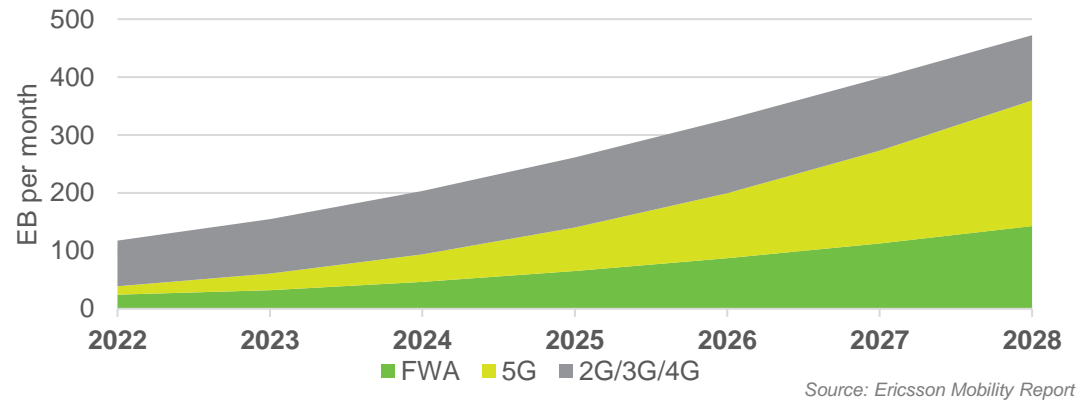

Demand for Wireless Transport Driven by Increasing Data Consumption

Rural Broadband Summary

Aviat E-Commerce Platform Leads Rural Broadband

Aviat is uniquely suited to serve WISPs through its Aviat Store and AviatCloud applications like Design (network planning and product recommendation) and automated radio and license applications

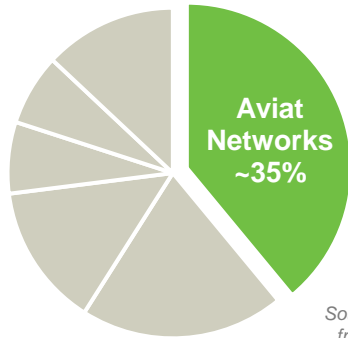

Source: PCN data from Comsearch

Leading wireless transport share of demand for North American ISPs

Wireless Transport is the Solution

Wireless transport is ideal for rural communities and is lower cost, more reliable, and faster to deploy than fiber

Growing number of Fixed Wireless Access (FWA) deployments favors wireless backhaul

Estimate the USA rural broadband segment to be a ~\$420M TAM

Over \$70B in Available Funding

\$1.5 Billion	CAF II
\$20 Billion	Rural Digital Opportunity Fund (RDOF)
\$9 Billion	5G Fund for Rural America
\$42.5 Billion	Broadband Equity, Access, and Deployment (BEAD) Program
\$635 Million	USDA Reconnect Program

Large Investments in Broadband Infrastructure Creates Opportunities for Wireless Transport

Aviat Operating Model Framework

Excellence in

Customer Focus



Innovation



Talent



Supply Chain



Our Actions

We listen during the commercial and sales process to understand our customers' needs and use our combined talents, skill and capabilities to create solutions that exceed expectations.

We deliver innovative, high-quality solutions that meet key customer segment needs. Voice of customer informs investment decisions. Release to market within budget, timeframe and scope.

We drive a performance culture and invest in our talent management programs to support evolving strategic business needs and implement organizational structures to facilitate results.

We achieve a competitive advantage by delivering quality products with best-in-class lead-times.

Our Processes

- Standard global VOC process
- Sales Goal planning
- eCommerce platform
- AviatCare customer service and support

- Aviat Operating System for software
- New Product Introduction (NPI) process
- Portfolio management
- Agile development methodology

- Performance Management Process
- Career Framework
- Talent Management Review
- Employee Ownership Program

- S&OP Planning
- Next day delivery e-commerce
- Order to Cash process
- Strategic sourcing to meet customer objectives globally

Continuous Improvement | We Strive Everyday...

To improve, innovate and drive cost efficiency to achieve higher performance and to promote our continuous improvement culture

Aviat Operating Model Supports Growth-Centric Culture by Leveraging Continuous Improvement and Driving Competitive Excellence

Second Quarter Fiscal 2025 Financial Highlights and Historical Performance

Second Quarter Fiscal 2025 Highlights

Revenue & Non-GAAP Gross Margin

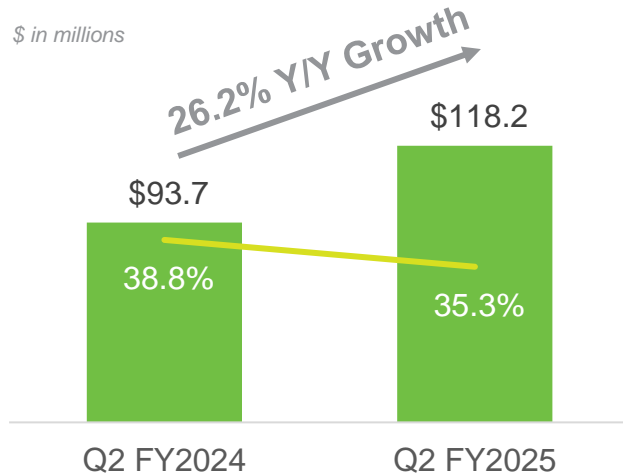

Adjusted EBITDA & Adj. EBITDA Margin

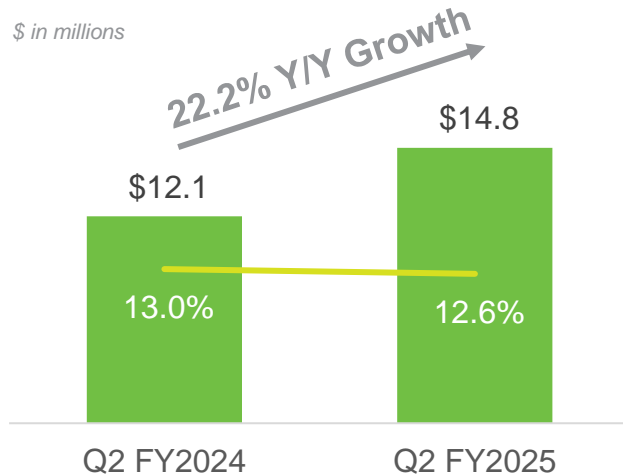

- Revenue of \$118.2 million, up 26.2% compared to the same period last year
 - TTM revenue of \$434.1M, up 22.7% versus year-ago period
- GAAP gross margin of 34.6%; Non-GAAP gross margin of 35.3%
- GAAP operating income of \$8.0 million; Non-GAAP operating income of \$12.6 million
- Adjusted EBITDA of \$14.8 million, up 22.2% compared to the same period last year
 - Record quarterly Adjusted EBITDA
- GAAP earnings per share of \$0.35; Non-GAAP earnings per share of \$0.82
- TTM book-to-bill above 1.0 in the quarter

Fiscal 2025 Guidance:

- Revenue: \$430.0 to \$470.0 million
- Adjusted EBITDA: \$30.0 to \$40.0 million

Focused on Increasing Revenue, Capturing Aviat's Differentiation and Driving Costs Out

Second Quarter Fiscal 2025 Balance Sheet Highlights

<i>(\$'s in millions, except for DSO, DPO and Turns)</i>	Q2 FY24 Actual	Q3 FY24 Actual	Q4 FY24 Actual	Q1 FY25 Actual	Q2 FY25 Actual
Cash Equivalents and Marketable Securities	\$45.9	\$58.2	\$64.6	\$51.0	\$52.6
Third-Party Debt	(\$49.5)	(\$48.9)	(\$48.4)	(\$83.4)	(\$74.9)
Net Cash and Marketable Securities	(\$3.6)	\$9.3	\$16.3	(\$32.3)	(\$22.3)
Accounts Receivable	\$148.5	\$136.5	\$158.0	\$169.0	\$166.7
Unbilled Receivables	\$74.4	\$71.5	\$90.5	\$94.7	\$93.9
Advance Payments and Unearned Revenue	(\$63.0)	(\$49.8)	(\$66.3)	(\$86.9)	(\$79.4)
DSO's	118	117	115	168	129
DSO's net of Unbilled/Unearned	126	131	133	185	138
Accounts Payable	(\$67.4)	(\$64.6)	(\$92.9)	(\$104.9)	(\$124.1)
DPO's	102	80	95	131	135
Inventory	\$68.0	\$58.2	\$62.3	\$79.6	\$76.5
Turns	4.6	4.7	5.0	3.9	4.0

Asset / (Liability)

- Cash and marketable securities of \$52.6 million
- Net debt of \$22.3 million, a sequential improvement of \$10 million
- Accounts receivable declined by \$2.3 million versus Q1 FY25
 - DSOs improved by 39 days and DSOs net of unbilled/unearned improved by 47 days
- Repurchased 34,600 shares in the quarter

Sequential Improvement in Net Debt Position by \$10 Million in the Quarter

Rolling Trailing Twelve Months Historical Performance

\$ in millions

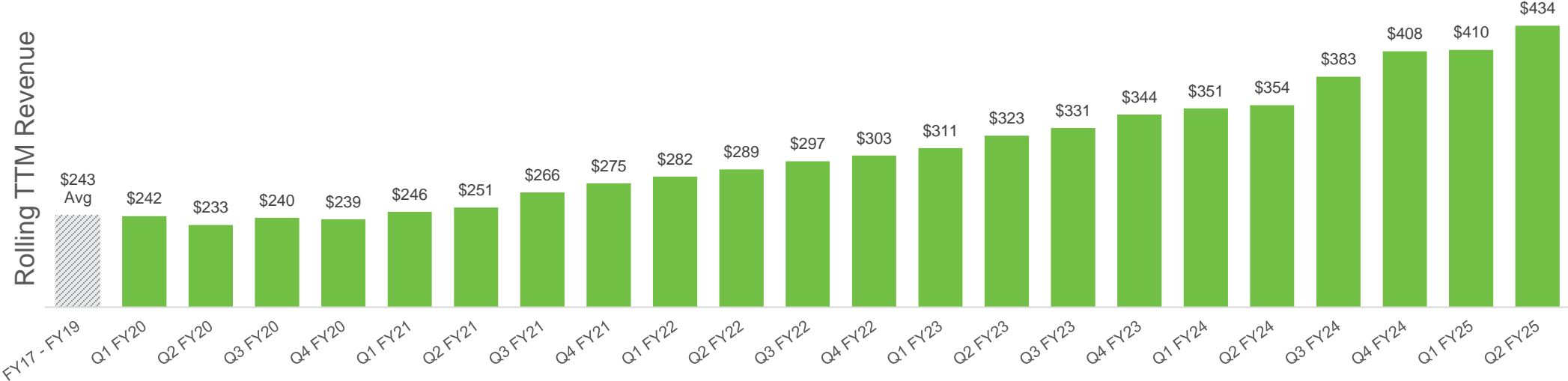

\$ in millions

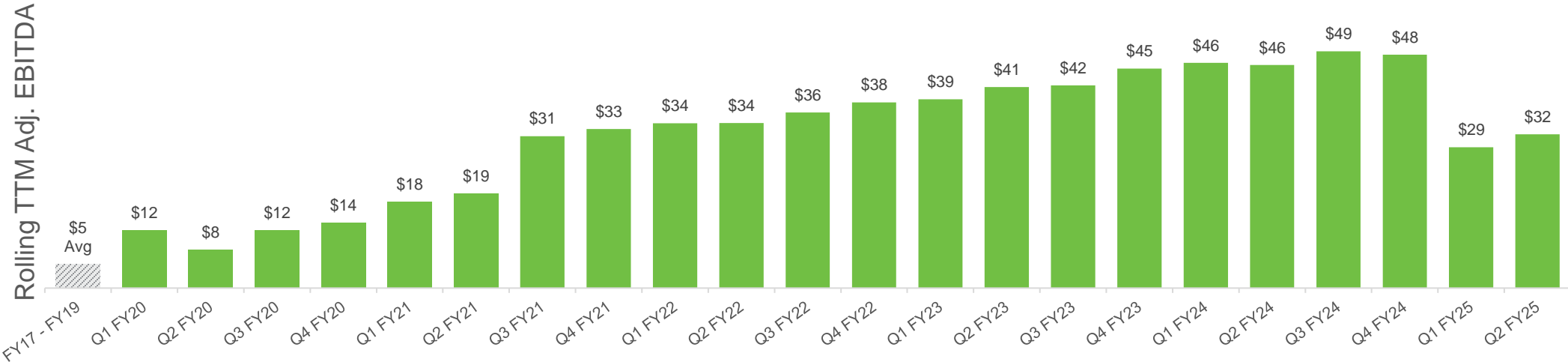

Cash Benefit of Historical Net Operating Losses (NOLs)

Total NOLs (M)

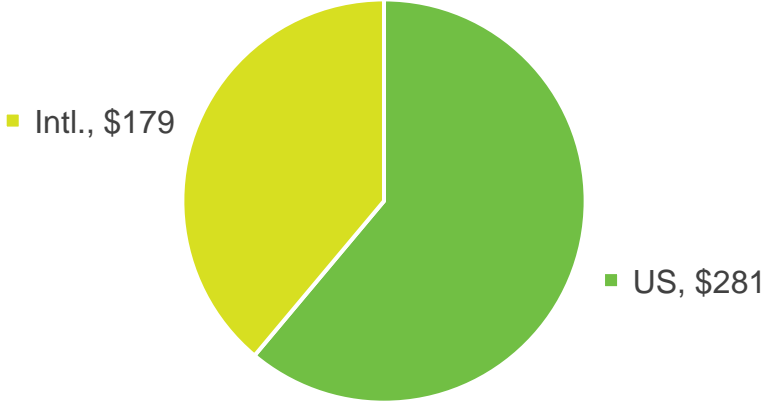

Deferred Tax Asset on AVNW Balance Sheet

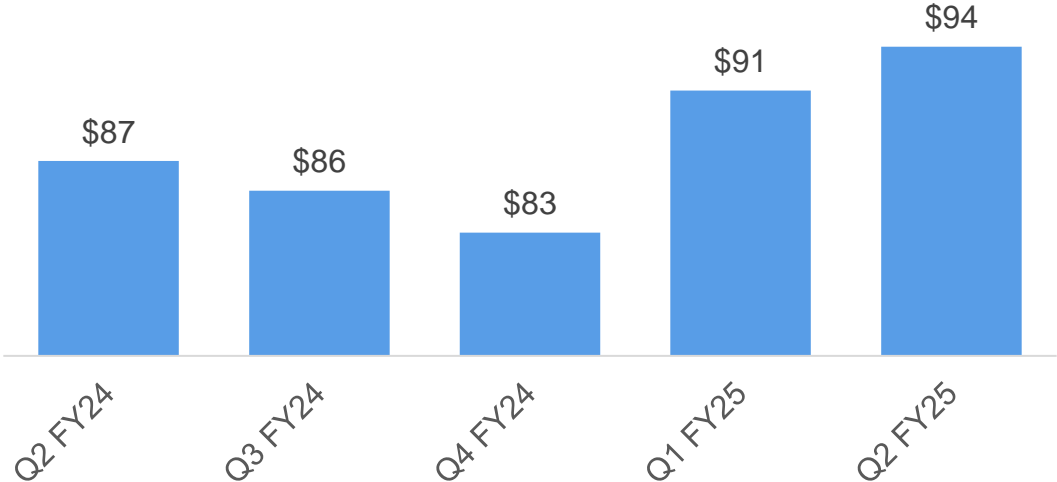

- \$460 million of gross NOLs
- NOL's reduce Aviat's statutory federal and state blended tax rate of ~25% to an effective cash tax rate of ~5%

- Improved financial performance and outlook for Aviat resulted in a full release of the valuation allowance against U.S. NOLs in Q3 of fiscal 2021
 - A one-time benefit of \$92 million was recognized in Net Income and Deferred Tax Assets

Cash Tax Savings Will Continue for the Foreseeable Future at Levels Commensurate with our Earnings Before Tax Performance

Revenue Pattern in Fiscal Year

\$ in millions

Fiscal Period	Q1	Q2	Q3	Q4
Calendar Period	Sep-ended Qtr	Dec-ended Qtr	Mar-ended Qtr	Jun-ended Qtr
Fiscal 2019 Revenue	\$60.5	\$65.1	\$54.0	\$64.2
<i>% of fiscal year revenue</i>	25%	27%	22%	26%
Fiscal 2020 Revenue	\$58.6	\$56.0	\$61.4	\$62.7
<i>% of fiscal year revenue</i>	25%	23%	26%	26%
Fiscal 2021 Revenue	\$66.3	\$70.5	\$66.4	\$71.7
<i>% of fiscal year revenue</i>	24%	26%	24%	26%
Fiscal 2022 Revenue	\$73.2	\$77.9	\$74.5	\$77.4
<i>% of fiscal year revenue</i>	24%	26%	25%	26%
Fiscal 2023 Revenue	\$80.8	\$90.4	\$82.2	\$91.1
<i>% of fiscal year revenue</i>	23%	26%	24%	26%
Fiscal 2024 Revenue	\$86.9	\$93.7	\$110.8	\$116.7
<i>% of fiscal year revenue</i>	21%	23%	27%	29%
Typical Revenue Contribution*	24%	26%	24%	26%

* excluding FY24 due to Pasolink acquisition

Typical Fiscal Quarter Revenue Contribution

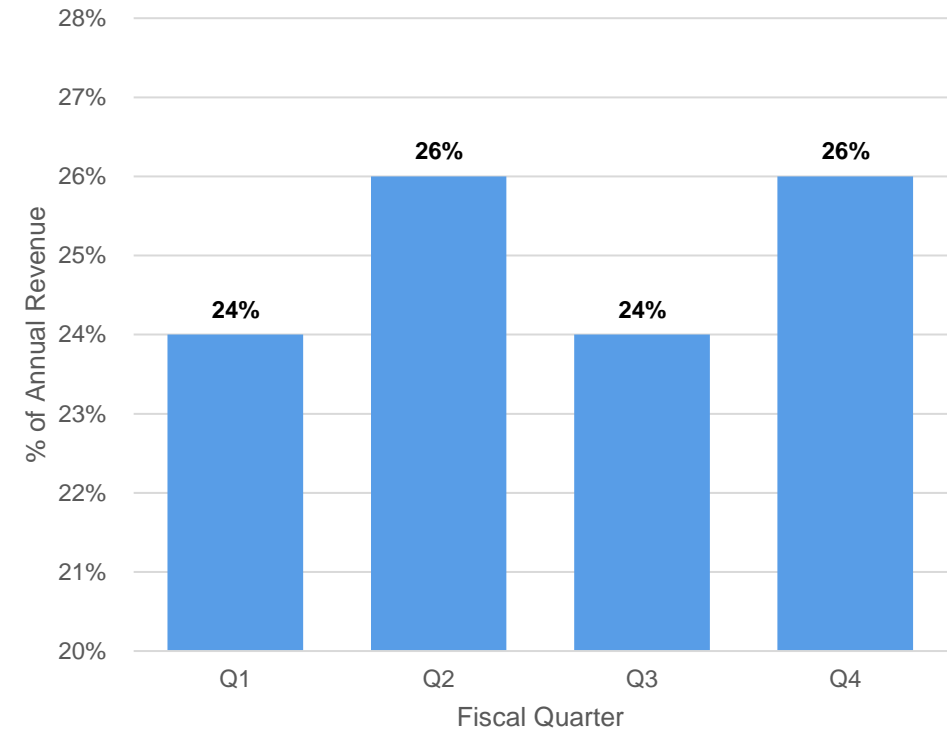

Fiscal Q2 and Q4 Tend to be Revenue High-Points in the Fiscal Year

GAAP to Non-GAAP Reconciliation

Fiscal Year 2025 Second Quarter Summary
RECONCILIATIONS OF NON-GAAP FINANCIAL MEASURES ⁽¹⁾
 Condensed Consolidated Statements of Operations
 (Unaudited)

	Three Months Ended				Six Months Ended			
	27-Dec-24	% of Revenue	29-Dec-23	% of Revenue	27-Dec-24	% of Revenue	29-Dec-23	% of Revenue
(In thousands, except percentages and per share amounts)								
GAAP gross margin	\$40,886	34.6%	\$36,327	38.8%	\$60,674	29.4%	\$67,522	37.4%
Share-based compensation	111		1		215		184	
Merger and acquisition and other expenses	693		66		1,300		109	
Non-GAAP gross margin	41,690	35.3%	36,394	38.8%	62,189	30.1%	67,815	37.5%
GAAP research and development expenses	\$10,222	8.6%	\$8,394	9.0%	\$20,630	10.0%	\$14,818	8.2%
Share-based compensation	(164)		(151)		(307)		(297)	
Non-GAAP research and development expenses	10,058	8.5%	8,243	8.8%	20,323	9.8%	14,521	8.0%
GAAP selling and administrative expenses	\$21,279	18.0%	\$22,544	24.1%	\$46,227	22.4%	\$41,781	23.1%
Share-based compensation	(1,699)		(1,673)		(3,116)		(3,178)	
Merger and acquisition and other expenses	(514)		(3,723)		(4,295)		(6,394)	
Non-GAAP selling and administrative expenses	19,066	16.1%	17,148	18.3%	38,816	18.8%	32,209	17.8%
GAAP operating income (loss)	\$7,970	6.7%	\$3,389	3.6%	(\$7,598)	(3.7%)	\$8,279	4.6%
Share-based compensation	1,974		1,825		3,638		3,659	
Merger and acquisition and other expenses	1,207		3,789		5,595		6,503	
Restructuring charges	1,415		2,000		1,415		2,644	
Non-GAAP operating income	12,566	10.6%	11,003	11.7%	3,050	1.5%	21,085	11.7%
GAAP income tax provision (benefit)	\$1,626	1.4%	\$1,848	2.0%	(\$3,888)	(1.9%)	\$2,280	1.3%
Adjustment to reflect pro forma tax rate	(1,126)		(1,548)		4,888		(1,680)	
Non-GAAP income tax provision	500	0.4%	300	0.3%	1,000	0.5%	600	0.3%

	Three Months Ended				Six Months Ended			
	27-Dec-24	% of Revenue	29-Dec-23	% of Revenue	27-Dec-24	% of Revenue	29-Dec-23	% of Revenue
(In thousands, except percentages and per share amounts)								
GAAP net income (loss)	\$4,495	3.8%	\$1,784	1.9%	(\$7,384)	(3.6%)	\$5,341	3.0%
Share-based compensation	1,974		1,825		3,638		3,659	
Merger and acquisition and other expenses	1,207		3,789		5,595		6,503	
Restructuring charges	1,415		2,000		1,415		2,644	
Other expense (income), net	269		(637)		979		165	
Adjustment to reflect pro forma tax rate	1,126		1,548		(4,888)		1,680	
Non-GAAP net income (loss)	\$10,486	8.9%	\$10,309	11.0%	(\$645)	(0.3%)	\$19,992	11.1%
Diluted net income (loss) per share:								
GAAP	\$0.35		\$0.15		(\$0.58)		\$0.44	
Non-GAAP	\$0.82		\$0.84		(\$0.05)		\$1.65	
Shares used in computing diluted net income (loss) per share								
GAAP	12,784		12,229		12,667		12,093	
Non-GAAP	12,784		12,229		12,802		12,093	
Adjusted EBITDA:								
GAAP net income (loss)	\$4,495	3.8%	\$1,784	1.9%	(\$7,384)	(3.6%)	\$5,341	3.0%
Depreciation and amortization of property, plant and equipment and intangible assets	2,275		1,140		4,105		2,484	
Interest expense, net	1,580		394		2,695		493	
Other expense (income), net	269		(637)		979		165	
Share-based compensation	1,974		1,825		3,638		3,659	
Merger and acquisition and other expenses	1,207		3,789		5,595		6,503	
Restructuring charges	1,415		2,000		1,415		2,644	
Provision for (benefit from) for income taxes	1,626		1,848		(3,888)		2,280	
Adjusted EBITDA	\$14,841	12.6%	\$12,143	13.0%	\$7,155	3.5%	\$23,569	13.1%

(1) The adjustments above reconcile our GAAP financial results to the non-GAAP financial measures used by us. Our non-GAAP net income excluded share-based compensation, and other non-recurring charges (recovery). Adjusted EBITDA was determined by excluding depreciation and amortization on property, plant and equipment, interest, provision for or benefit from income taxes, and non-GAAP pre-tax adjustments, as set forth above, from GAAP net income. We believe that the presentation of these non-GAAP items provides meaningful supplemental information to investors, when viewed in conjunction with, and not in lieu of, our GAAP results. However, the non-GAAP financial measures have not been prepared under a comprehensive set of accounting rules or principles. Non-GAAP information should not be considered in isolation from, or as a substitute for, information prepared in accordance with GAAP. Moreover, there are material limitations associated with the use of non-GAAP financial measures.



Aviat
NETWORKS



WWW.AVIATNETWORKS.COM